

ANKAme STATIC LINE CORRECT INSTALLATION USER MANUAL

(TEMPORARY / PERMANENT APPLICATION 360 DEGREE USE)

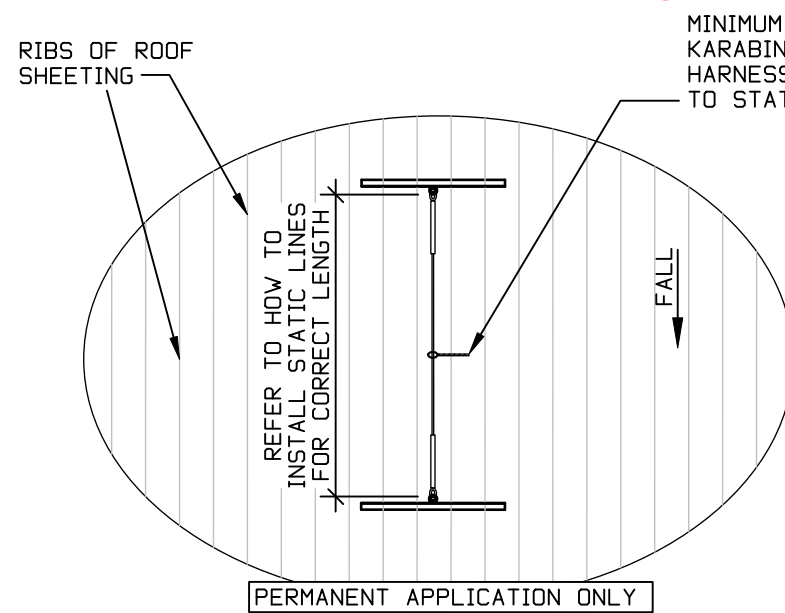

TYPE 1 LINE CONFIGURATION

PERMANENT APPLICATION ONLY
 SINGLE LINE PERMANENT APPLICATION ONLY
 END ANCHORAGE WITH TWO (2) ANKAme ANCHORS
 LINE INITIALLY PARALLEL TO RIBS OF ROOF SHEETING
 ONE PERSON PER SYSTEM (ROOF PITCH UPTO 15°)

MINIMUM 15 kN RATED SLIDER,
 KARABINA OR END HOOK ON
 HARNESS ROPE CAN BE CONNECTED
 TO STATIC LINE AS PER AS/NZS

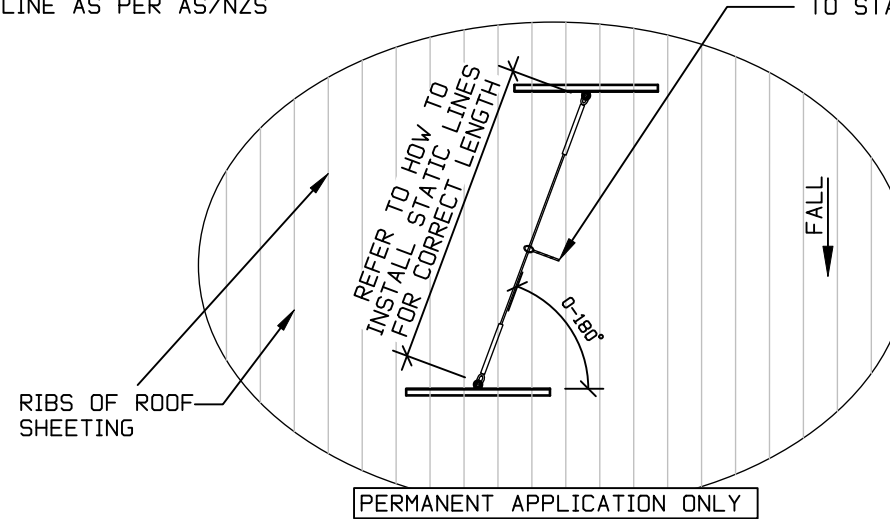

TYPE 2 LINE CONFIGURATION

PERMANENT APPLICATION ONLY
 SINGLE LINE PERMANENT APPLICATION ONLY
 END ANCHORAGE WITH TWO (2) ANKAme ANCHORS
 LINE INITIALLY DIAGONAL TO RIBS OF ROOF SHEETING
 ONE PERSON PER SYSTEM (ROOF PITCH UPTO 15°)

MINIMUM 15 kN RATED SLIDER,
 KARABINA OR END HOOK ON
 HARNESS ROPE CAN BE CONNECTED
 TO STATIC LINE AS PER AS/NZS

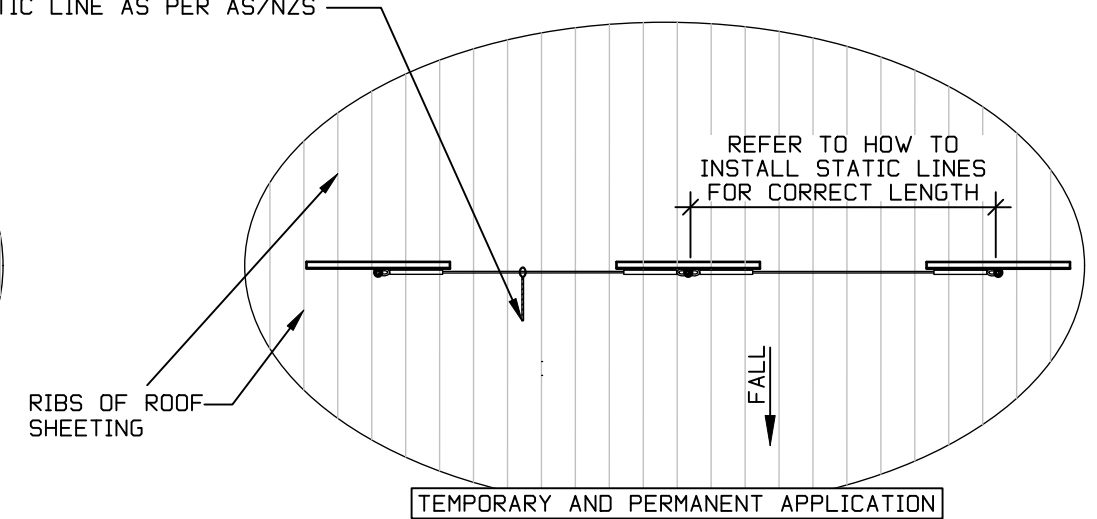

TYPE 3 LINE CONFIGURATION

TEMPORARY AND PERMANENT APPLICATION
 MULTIPLE LINES UPTO 300 METERS
 CUSTOM ORB/SPANDEK TEMPORARY FIX FOR TIMBER FIX ONLY
 LINE INITIALLY NORMAL TO RIBS OF ROOF SHEETING
 ONE PERSON EVERY SECOND SPAN (ROOF PITCH UPTO 40°)

NOTES:

- FOR GENERAL REQUIREMENTS OF SAFETY LINES INCLUDING MATERIALS, WHERE AND HOW THEY ARE TO BE USED, REFER TO AS/NZS AS LISTED AT THE BOTTOM OF THIS DOCUMENT.
- THE END ANCHORAGES ARE DESIGNED FOR SPECIFIC SAFETY LINE MATERIALS. OTHER STATIC LINE SYSTEMS ARE **NOT** TO BE USED WITH THE ANKAme END ANCHORS. ANKAme STATIC LINES ARE TO BE INSTALLED AND USED **ONLY** AS SPECIFIED IN THIS DOCUMENT.
- END ANCHORS WITH STATIC LINES FIXED ON ROOF SHEETING TO BE INSTALLED AS PER TYPE 1 TO TYPE 3 CONFIGURATION. REFER TO HOW TO INSTALL STATIC LINES FOR SUITABILITY OF PERMANENT AND TEMPORARY APPLICATION FOR EACH TYPE OF ROOF SHEETING.
- PERMANENT ROOF ANCHOR SYSTEM TO BE CHECKED EVERY 12 MONTHS BY A COMPETENT PERSON AS PER AS/NZS AND ANKAme USER MANUAL.

HOW TO INSTALL STATIC LINES:

- STATIC LINES CAN **ONLY** BE INSTALLED BY A COMPETENT PERSON AS PER AS/NZS AND ANKAme USER MANUAL.
- POSITION END ROOF ANCHORS INTO DESIRED WORKING LOCATION AND CONNECT STATIC LINE TO END EYE BOLTS BEFORE FASTENING ANCHORS TO ROOF, AS PER ANKAme USER MANUAL.
- SET STATIC LINE LENGTHS FROM INSIDE EDGE OF EYE BOLTS FOR EACH TYPE OF ROOF SHEETING AS BELOW:
 CUSTOM ORB - 7.575 METERS (PERMANENT & TEMPORARY APPLICATION FOR TIMBER FIX ONLY)
 TRIMDEK - 7.540 METERS (PERMANENT & TEMPORARY APPLICATION)
 SPANDEK - 7.685 METERS (PERMANENT & TEMPORARY APPLICATION FOR TIMBER FIX ONLY)
 KLIP-LOK 700 - 7.725 METERS (PERMANENT APPLICATION ONLY)
- WHEN TIGHTENING STATIC LINE:
 - ENSURE THERE IS A MINIMUM THREAD OF 7 MM ON EACH ADJUSTER
 - TIGHTEN THE ADJUSTER ON THE OPPOSITE END TO THE LOAD INDICATOR ADJUSTER
 - WHEN THE LOAD INDICATOR IS RELEASED AND SPINS FREELY THEN THE STATIC LINE IS SET AT CORRECT TOQUE
 - WARNING: DO NOT OVER TIGHTEN STATIC LINE LOAD INDICATOR. IF LOAD INDICATOR IS OVER TIGHTENED, IT MAY NOT WORK CORRECTLY UPON REUSING FOR TEMPORARY APPLICATION AND THE STATIC LINE WILL NEED TO BE REMOVED FROM SERVICE AND REPLACED WITH A NEW STATIC LINE
- TEMPORARY ANCHORS CAN BE UNDONE AND REMOVED FOLLOWING REVERSED ABOVE-MENTIONED INSTALLATION SEQUENCE. HOWEVER, PERMANENT ANCHORS CAN **NOT** BE REMOVED.

NOTE:
**IF SITE CONDITIONS VARY,
 OR IF ROOF STRUCTURE IN
 DOUBT, CONSULT ENGINEER**

ANKAme ROOF ANCHORS FIXED TO ROOF SHEETING IN ACCORDANCE WITH OWNERS MANUAL CORRECT INSTALLATION ON PAGE 2 OF THIS DOCUMENT, PREPARED BY ANKAme PTY LTD - TYPICAL

IMPORTANT NOTE:
 THE EXISTING ROOF SHEETING AND ITS IMMEDIATE SUPPORTS ARE TO BE CHECKED BY A COMPETENT PERSON FOR STRUCTURAL INTEGRITY AND FOR INSTALLATION COMPLIANCE WITH ITS MANUFACTURERS SPECIFICATIONS, PRIOR TO ANKAme ROOF ANCHORS BEING INSTALLED.

TABLE : ROOF SHEET AND FIXING TYPE			
TYPE OF ROOF SHEETING	TYPE OF APPLICATION	SUITABLE TYPE OF LINE CONFIGURATION	SET STATIC LINE LENGTHS (METERS)
CUSTOM ORB	PERMANENT	TYPE 1 & 2 & 3	7.575
	TEMPORARY	TYPE 3 (TIMBER FIX ONLY)	
TRIMDEK	PERMANENT	TYPE 1 & 2 & 3	7.540
	TEMPORARY	TYPE 3	
SPANDEK	PERMANENT	TYPE 1 & 2 & 3	7.685
	TEMPORARY	TYPE 3 (TIMBER FIX ONLY)	
KLIP-LOK 700	PERMANENT	TYPE 1 & 2 & 3	7.725
	TEMPORARY	NOT TO USE	

STRUCTURAL CERTIFICATION
 ROSS ENGINEERS CAN CERTIFY THAT THE WORK PROPOSED IN THIS STRUCTURAL DRAWING, AS UNDERTAKEN IN ACCORDANCE WITH ALL CONSTRUCTION NOTES IN THIS DRAWING IS IN ACCORDANCE WITH THE FOLLOWING CODES
 AS/NZS 1170.0: 2002 - "STRUCTURAL DESIGN ACTIONS - GENERAL PRINCIPLES"
 AS/NZS 1891.2:2001 - SUPPLEMENT 1: 2001 "INDUSTRIAL FALL-ARREST SYSTEMS AND DEVICES" PART 2: HORIZONTAL LIFELINE AND RAIL SYSTEMS
 AS/NZS 1891.4:2009 - "INDUSTRIAL FALL-ARREST SYSTEMS AND DEVICES" PART 4: SELECTION, USE AND MAINTENANCE

SIGNATURE: *J. Kantouros*
 JOHN KANTOUIROS (CIVIL/STRUCTURAL ENGINEER)
 B.Eng (CIVIL) HONOURS, MIEAust CPEng NER-768626
 DATE: 22/04/2022

NOTE: IF REFERENCED STANDARDS BECOME SUPERSEDED CERTIFICATION IS NOT TO BE RELIED UPON

DRAWING LIST	
PAGE 1 OF 2	ANKAme STATIC LINE CORRECT INSTALLATION USER MANUAL
PAGE 2 OF 2	ANKAme OWNERS MANUAL CORRECT INSTALLTION

1	CC	2022.04.22
ISSUE	REVISION DESCRIPTION	DATE

ROSS ENGINEERS
 CONSULTING STRUCTURAL ENGINEERS
 357 GLEBE POINT ROAD GLEBE NSW 2037
 PHONE (02) 9518 9373
 EMAIL info@rossengineers.com.au
 WEB www.rossengineers.com.au

CLIENT: ANKAme PTY LTD		TITLE: STATIC LINE CONFIGURATIONS TYPE 1 TO TYPE 3	
PROJECT: ANKAme ROOF ANCHOR ANCHORAGE USING STATIC LINE CONFIGURATIONS	Sheet No: 1 OF 2	Drawn: JL	Designed: JK
	Approved: JK	Size: A3	Scale: NOT TO SCALE
	Drawing No: 22-0261-ST		

Registered Design Copyright © 2010

NOTE

USE, INSPECTION AND MAINTENANCE

It is a requirement that the roof anchor be visually inspected prior to each use, if any of the following are evident, the roof anchor must be removed from service immediately: Any defects, absent markings / labelling, evidence of missing parts, or if the roof anchor has been used in a fall. Roof anchor not to be used in a corrosive environment. Temporary fix not to be used as a permanent fixture. Roof anchor to be used in the direction of eyebolt only. Roof anchor to be used only where roof sheeting has been fully installed in accordance with manufacturers recommendations. Roof sheeting profile can vary up to 5mm, inspect roof sheeting prior to installation of roof anchor. Roof anchor to be cleaned regularly with a damp cloth.

IMPORTANT

All specified fastenings must be fixed into adequate roof structure, if adequacy of the roof structure is in doubt, the roof should be inspected and certified by a registered structural engineer. It is the responsibility of the installer and user for the correct use of the anchor. It is recommended that the roof anchor be fixed 2500mm from edge of roof and no less than 800mm from edge of roof. Other fastenings are NOT to be used with the roof anchor. Shock absorber equipment must be attached at all times. For correct use of equipment, refer to AS/NZS 1891.4: 2009 , industrial fall-arrest systems and devices - selection, use and maintenance. People with any disability, impaired vision or other impaired capabilities are not to use the roof anchor. Min grade of timber to be F8, min grade of steel to be G450. Temporary fix custom orb timber fix only. If product is misused death or serious injury may result.

Permanent fix (min grade sheet thickness 0.42mm) with 1 Fab-Lok EZJ120 or with 1 x Bulb-tite 7.7mm x 27mm RV6605-9-6W fixed in sequence as indicated below. **to be installed and used by competent persons only.**

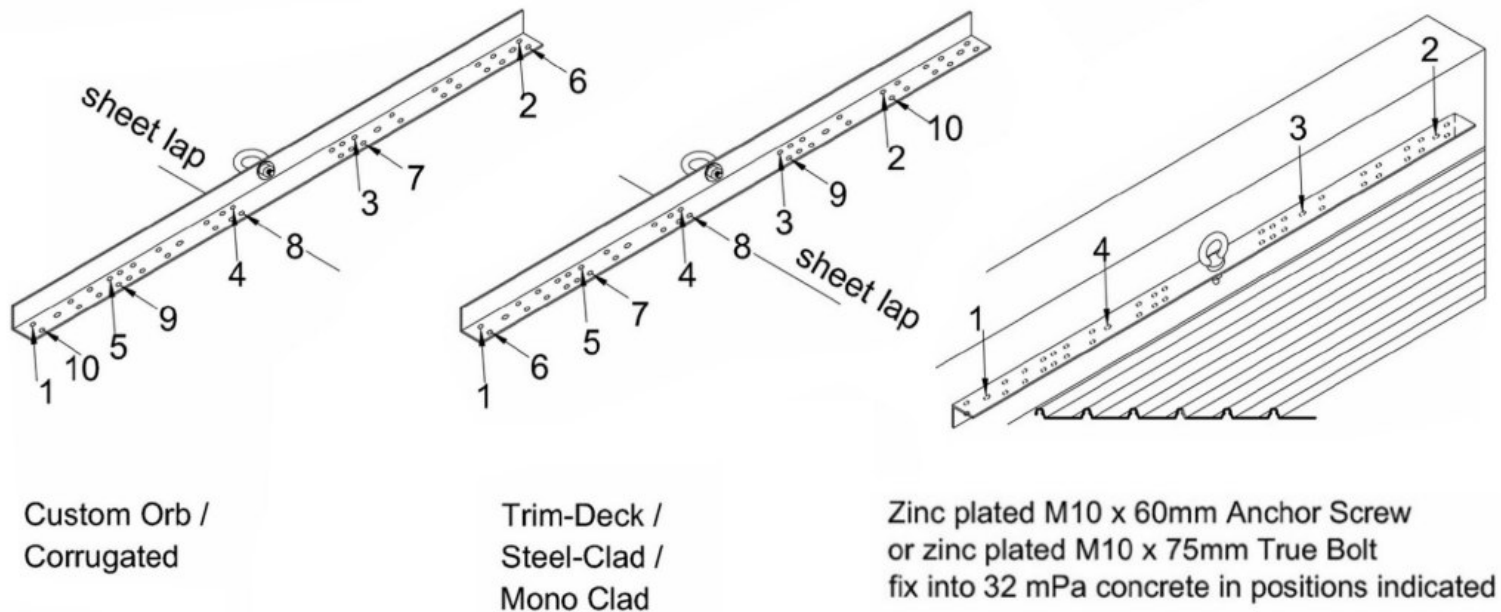
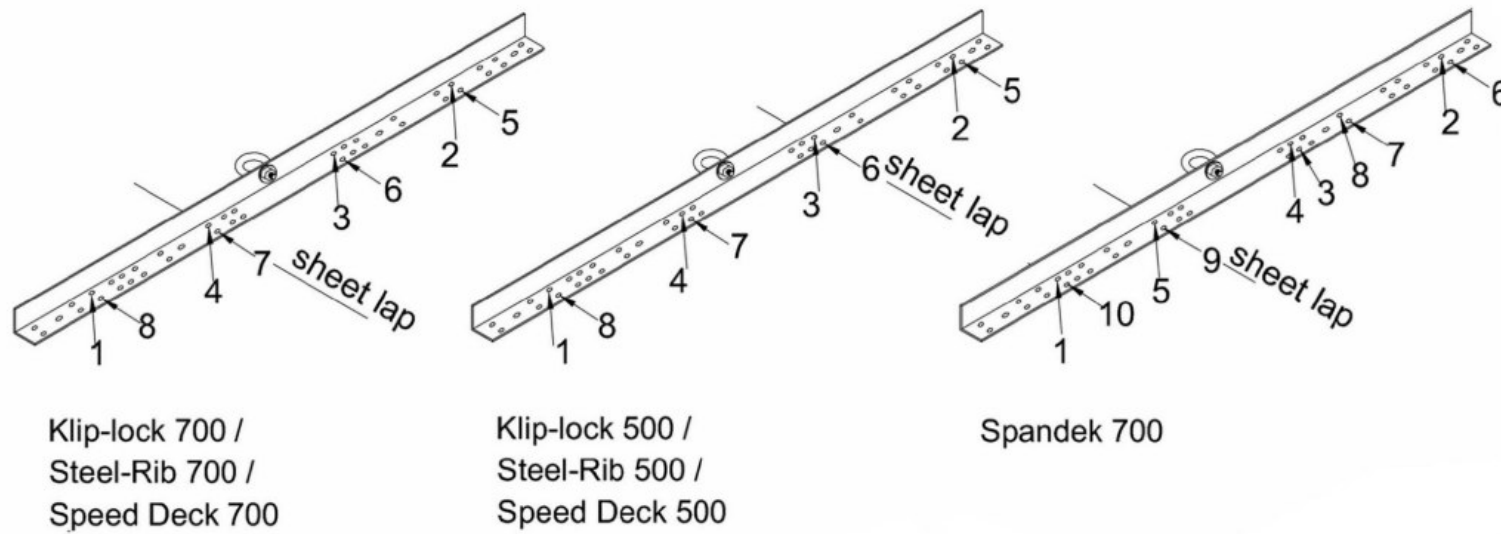

Temporary fix (min grade sheet thickness 0.42mm) with 1 x Bremick 14-20 x 65mm fixed in sequence as indicated below. **to be installed and used by competent persons only.**

